

GENERAL DESCRIPTION

The SGM6605 is a constant frequency, current mode, synchronous Boost switching regulator. The input voltage can accept the voltage at a range from 2.7V to 5.5V. And the output voltage is adjustable with a peak of 5.2V. This device also has the 5.0V fixed output version.

High switching frequency minimizes the sizes of inductor and capacitor. Integrated power MOSFETs and internal compensation make the SGM6605 simple to use and fit the total solution into a compact space.

The SGM6605 enters the power-save mode at light loads to maintain high efficiency. Anti-ringing control circuitry reduces EMI concerns by damping the inductor in discontinuous mode. The SGM6605 provides true output disconnection, allowing V_{OUT} to go to 0V during shutdown without drawing any current from the input source. The SGM6605 supports 1.8V logic for control.

The output voltage of SGM6605-ADJ can be programmed by an external resistor divider, and that of SGM6605-5.0 is fixed internally on the chip. The device is available in a Green SOT-23-6 package. It operates over an ambient temperature range of -40°C to +85°C.

FEATURES

- 2.7V to 5.5V Input Voltage Range
- 5.0V Fixed Output Voltage
- Adjustable Output Voltage up to 5.2V
- Up to 90% Efficiency
- 30µA (TYP) Quiescent Current
- 1µA (MAX) Shutdown Current
- 6V Output Voltage Clamping
- Improved Light Load Efficiency with Power-Save Mode (PSM)
- Load Disconnected in Shutdown Mode
- 1.8V Logic on EN Pin for Control
- Low Reverse Leakage Current when $V_{OUT} > V_{IN}$
- Over-Temperature Protection
- Available in a Green SOT-23-6 Package
- -40°C to +85°C Operating Temperature Range

APPLICATIONS

- Single-Cell Li Battery Powered Products
- Portable Audio Players
- Mobile Phones
- Personal Medical Devices

TYPICAL APPLICATION

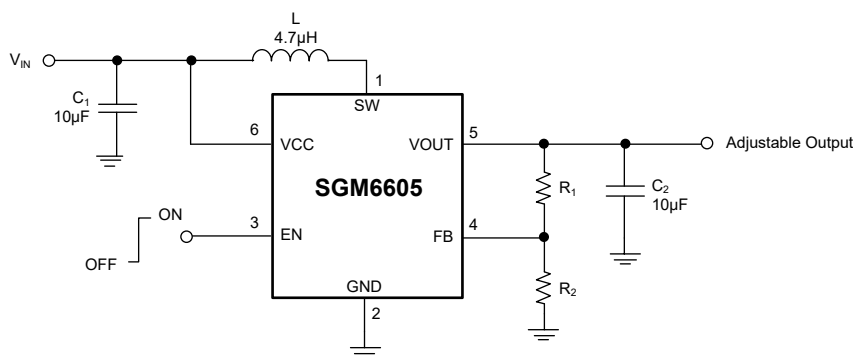

Figure 1. Typical Application Circuit

PACKAGE/ORDERING INFORMATION

MODEL	V _{OUT} (V)	PACKAGE DESCRIPTION	SPECIFIED TEMPERATURE RANGE	ORDERING NUMBER	PACKAGE MARKING	PACKING OPTION
SGM6605	Adjustable	SOT-23-6	-40°C to +85°C	SGM6605-ADJYN6G/TR	SI6XX	Tape and Reel, 3000
	5.0	SOT-23-6	-40°C to +85°C	SGM6605-5.0YN6G/TR	SI8XX	Tape and Reel, 3000

MARKING INFORMATION

NOTE: XX = Date Code.

YYY X X

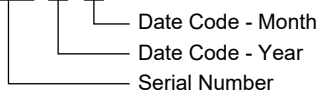

Green (RoHS & HSF): SG Micro Corp defines "Green" to mean Pb-Free (RoHS compatible) and free of halogen substances. If you have additional comments or questions, please contact your SGMICRO representative directly.

ABSOLUTE MAXIMUM RATINGS

Input Voltage Range on SW, VOUT, VCC, FB, EN
 -0.3V to 6V
 Package Thermal Resistance
 SOT-23-6, θ_{JA} 150°C/W
 Junction Temperature +150°C
 Storage Temperature Range -65°C to +150°C
 Lead Temperature (Soldering, 10s) +260°C
 ESD Susceptibility
 HBM 4000V
 MM 250V

RECOMMENDED OPERATING CONDITIONS

Operating Temperature Range -40°C to +85°C

OVERSTRESS CAUTION

Stresses beyond those listed in Absolute Maximum Ratings may cause permanent damage to the device. Exposure to absolute maximum rating conditions for extended periods may affect reliability. Functional operation of the device at any conditions beyond those indicated in the Recommended Operating Conditions section is not implied.

ESD SENSITIVITY CAUTION

This integrated circuit can be damaged if ESD protections are not considered carefully. SGMICRO recommends that all integrated circuits be handled with appropriate precautions. Failure to observe proper handling and installation procedures can cause damage. ESD damage can range from subtle performance degradation to complete device failure. Precision integrated circuits may be more susceptible to damage because even small parametric changes could cause the device not to meet the published specifications.

DISCLAIMER

SG Micro Corp reserves the right to make any change in circuit design, or specifications without prior notice.

PIN CONFIGURATION

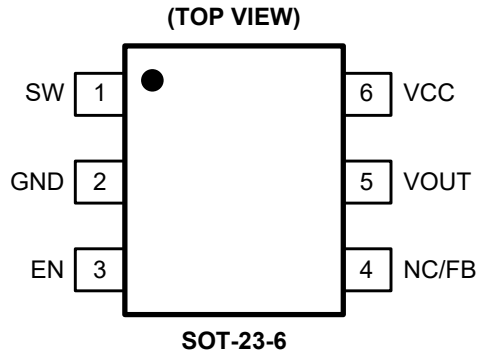

PIN DESCRIPTION

PIN	NAME	FUNCTION
1	SW	Boost and Rectifying Switch Input.
2	GND	Ground.
3	EN	Enable Input. (1/VCC enabled, 0/GND disabled)
4	NC	No Connect. It should be left floating. (SGM6605-5.0)
	FB	Output Voltage Feedback Pin. An external resistor divider programs the output voltage. (SGM6605-ADJ)
5	VOUT	Output.
6	VCC	Supply Voltage.

ELECTRICAL CHARACTERISTICS(Full = -40°C to +85°C, typical values are at $T_A = +25^\circ\text{C}$, unless otherwise noted.)

PARAMETER	SYMBOL	CONDITIONS	TEMP	MIN	TYP	MAX	UNITS
DC/DC Stage							
Output Voltage Range	V_{OUT}		Full	3.0		5.2	V
Input Voltage Range	V_{IN}		+25°C	2.7		5.5	V
Feedback Voltage	V_{FB}		Full	485	500	519	mV
Oscillator Frequency	f		Full	870	1200	1470	kHz
Switch Current Limit	I_{SW}		Full	0.75	1.1	1.45	A
Start-Up Current Limit			+25°C		300		mA
Boost Switch-On Resistance		$V_{OUT} = 5V$	+25°C		400		mΩ
Rectifying Switch-On Resistance		$V_{OUT} = 5V$	+25°C		530		mΩ
Output Voltage Accuracy		$V_{CC} = 2.7V, I_O = 10mA$	Full			3.8	%
Line Regulation		$V_{CC} = 2.7V$ to $V_{OUT} - 0.5V, I_O = 10mA$	Full		0.5	1	%
Load Regulation			+25°C		0.5		%
Quiescent Current	V_{CC}	$V_{EN} = V_{CC} = 2.7V, I_O = 0mA$	Full		0.1	1	μA
	V_{OUT}	$V_{EN} = V_{CC} = 2.7V, I_O = 0mA, V_{OUT} = 5V$	+25°C		30	55	
Shutdown Current		$V_{EN} = 0V, V_{CC} = 2.7V$	+25°C			1	μA
Control Stage							
EN Input Low Voltage	V_{IL}		Full			0.4	V
EN Input High Voltage	V_{IH}		Full	1.6			V
EN Input Current		Clamped on GND or VCC	Full			1	μA
Over-Temperature Protection					150		°C
Over-Temperature Hysteresis					20		°C

TYPICAL PERFORMANCE CHARACTERISTICS

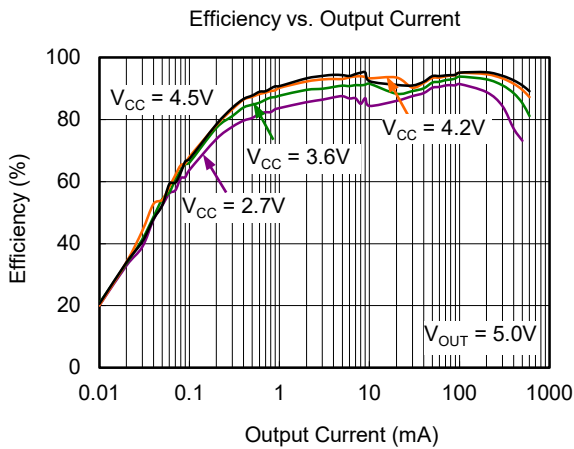
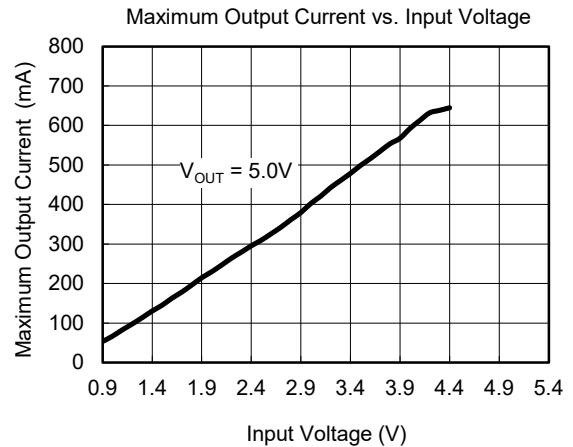
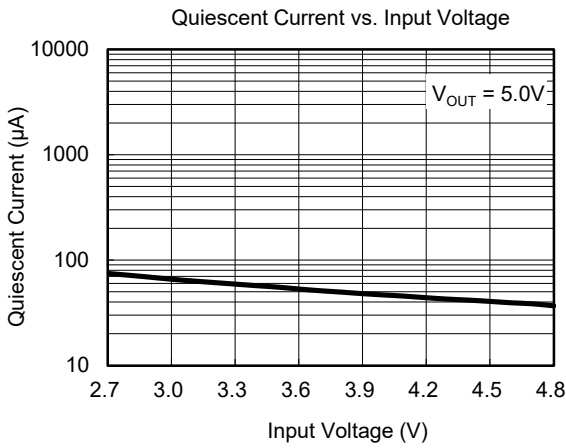
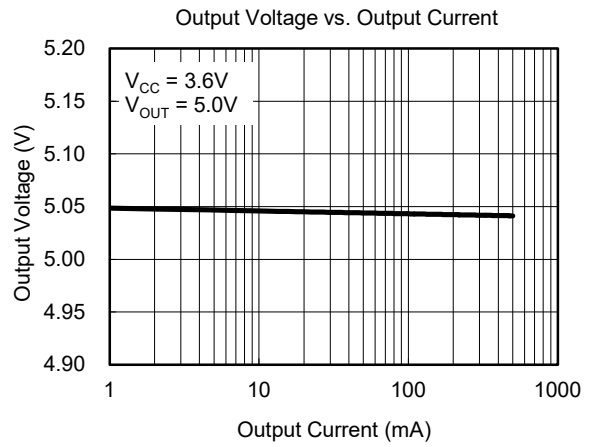
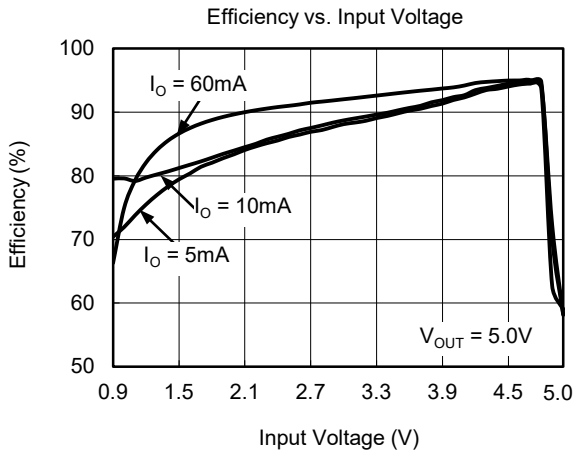

TYPICAL PERFORMANCE CHARACTERISTICS (continued)

Line Transient Response

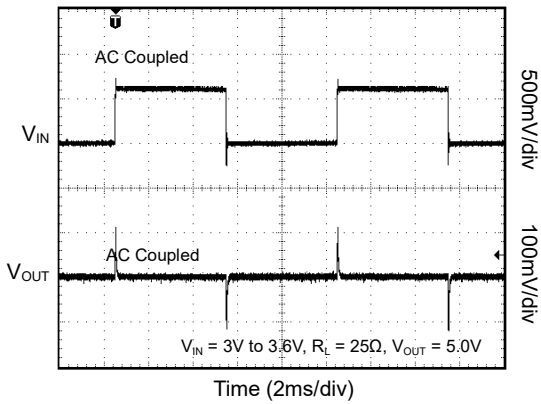

Load Transient Response

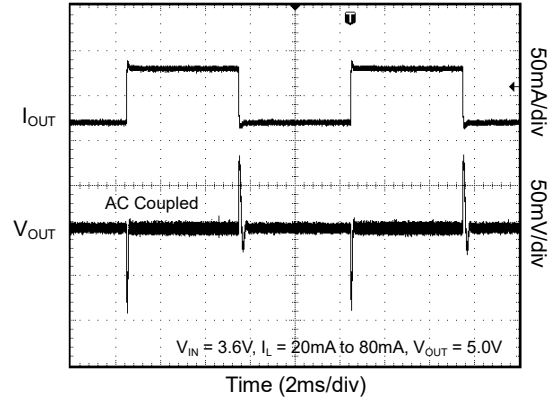

Start-Up after Enable

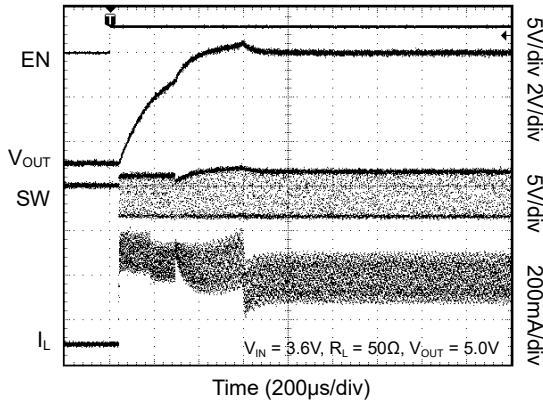

Output Voltage in Continuous Mode

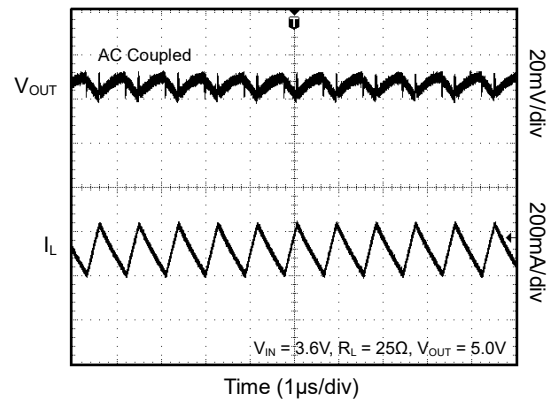

Output Voltage in Power-Save Mode

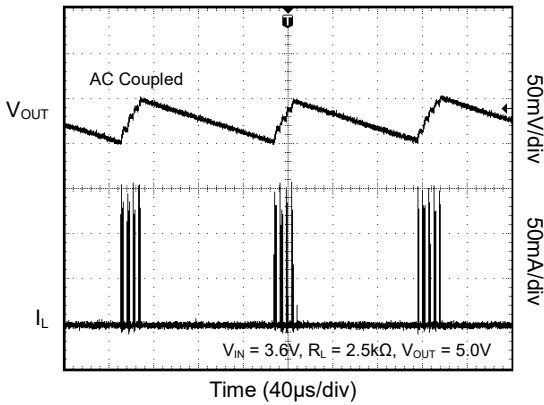

TYPICAL APPLICATION CIRCUITS

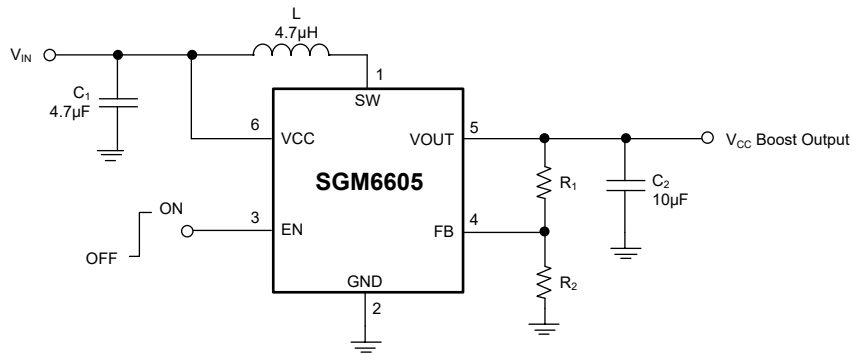

Figure 2. Small Total Solution Size Power Supply Circuit

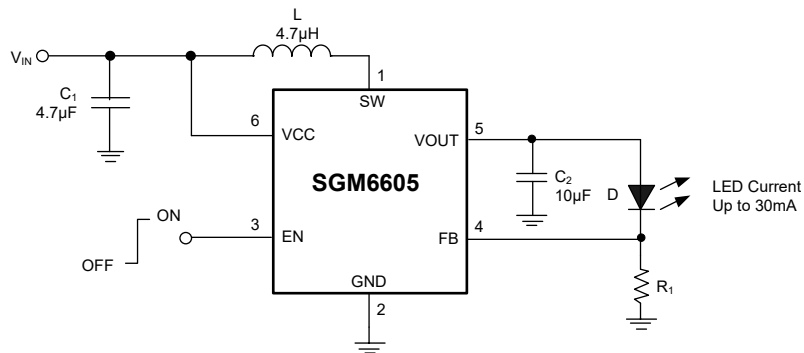

Figure 3. Circuit of Powering White LEDs in Lighting Applications

APPLICATION INFORMATION

Design

The SGM6605 is a synchronous Boost converter capable of starting up from 2.7V input, which is suitable for majority of readily available input sources. The device is capable of providing up to 5.2V output, and the integrated power MOSFET has 1.1A (TYP) switch current limit.

Output Voltage Configuration

The SGM6605 supports output voltage up to 5.2V, and a resistor divider connected at FB pin is used to configure the output voltage. The resistive divider value is calculated via Equation 1.

$$\frac{V_{OUT} - V_{FB}}{R_1} = \frac{V_{FB}}{R_2} \quad (1)$$

For simplicity, 100k Ω is recommended for R₂. A 900k Ω resistor for R₁ configures the output voltage to 5V.

Inductor Selection

Inductor is an essential element for today's DC/DC switch mode power supplies regardless of topology. Inductor serves as the energy storage element for power conversion. Inductance and inductor's saturation current are two most important criterions for inductor selection. For general rule of thumb, the selected inductance should provide a peak to peak ripple current that is around 30% of the average inductor current at full load and nominal input voltage. The average inductor current for a Boost converter is the input current. Equation 2 shows the calculation of inductance selection, where f is the switching frequency, ΔI_L is the inductor ripple current.

$$L = \frac{V_{CC}}{\Delta I_L \times f_{SW}} \times \left(1 - \frac{V_{IN}}{V_O}\right) \quad (2)$$

The selected inductor should have a saturation current rating higher than the 1.1A current limit of SGM6605.

Lastly, the inductor affects the close loop response of the DC/DC converter. The SGM6605 is an internally compensated device with the loop response optimized for inductor in the range of 2.2 μ H to 10 μ H.

Input Capacitor

Boost converter's input capacitor sees continuous current throughout the entire switching cycle. A 10 μ F

ceramic capacitor is recommended to place as close as possible between the VCC pin and GND pin of SGM6605. For the applications where the SGM6605 is located far away from the input source, a 47 μ F or higher capacitance capacitor is recommended to damp the wiring harness's inductance.

Output Capacitor

The output capacitors of Boost converter dictate the output voltage ripple and load transient response. Equation 3 is used to estimate the necessary capacitance to achieve desired output voltage ripple. Where ΔV is the maximum allowed ripple.

$$C_{MIN} = \frac{I_O \times (V_{OUT} - V_{CC})}{f \times \Delta V \times V_{OUT}} \quad (3)$$

Again, the SGM6605 is an internally compensated device. The loop response is optimized for capacitor in the range of 4.7 μ F to 22 μ F. Due to the DC bias nature of ceramic capacitors, care should be taken by verifying manufacture's datasheet to ensure enough effective capacitance at desired output voltage.

Layout Guidelines

In addition to component selection, layout is a critical step to ensure the performance of any switch mode power supplies. Poor layout could result in system instability, EMI failure, and device damage. Thus, place the inductor, input and output capacitors as close to the IC as possible, and use wide and short traces for current carrying traces to minimize PCB inductance.

For Boost converter, the output capacitor's current loop from VOUT pin back to the GND pin of the device should be as small as possible.

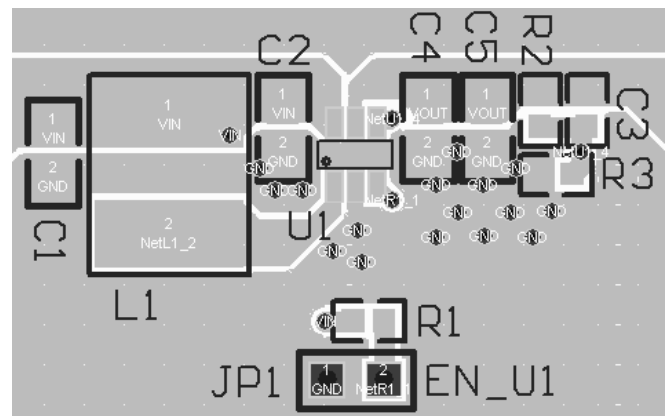

Figure 5. Layout Example

REVISION HISTORY

NOTE: Page numbers for previous revisions may differ from page numbers in the current version.

	Page
MAY 2022 – REV.B to REV.B.1	
Updated Application Information section.....	8
NOVEMBER 2021 – REV.A.4 to REV.B	
Added the Figure 5. Layout Example section.....	8
JULY 2020 – REV.A.3 to REV.A.4	
Changed Maximum Output Voltage	1, 4, 5, 8
FEBRUARY 2018 – REV.A.2 to REV.A.3	
Update the Typical Performance Characteristics Efficiency vs. Input Voltage ($V_{OUT} = 5.0V$)	5
DECEMBER 2013 – REV.A.1 to REV.A.2	
Update the Electrical Characteristics Switch Current Limit	4
JUNE 2013 – REV.A to REV.A.1	
Update the Typical Performance Characteristics Efficiency vs. Output Current and Output Voltage vs. Output Current	6
Changes from Original (JANUARY 2013) to REV.A	
Changed from product preview to production data.....	All

PACKAGE OUTLINE DIMENSIONS

SOT-23-6

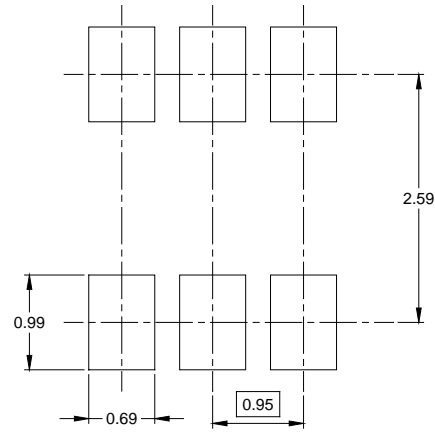
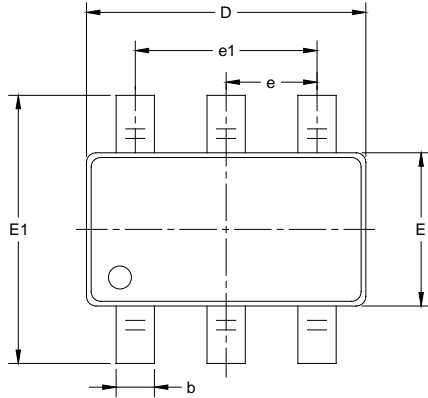

RECOMMENDED LAND PATTERN (Unit: mm)

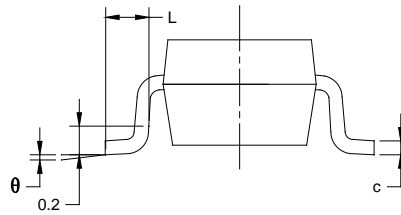
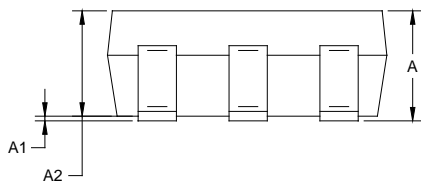

Symbol	Dimensions In Millimeters		Dimensions In Inches	
	MIN	MAX	MIN	MAX
A	1.050	1.250	0.041	0.049
A1	0.000	0.100	0.000	0.004
A2	1.050	1.150	0.041	0.045
b	0.300	0.500	0.012	0.020
c	0.100	0.200	0.004	0.008
D	2.820	3.020	0.111	0.119
E	1.500	1.700	0.059	0.067
E1	2.650	2.950	0.104	0.116
e	0.950 BSC		0.037 BSC	
e1	1.900 BSC		0.075 BSC	
L	0.300	0.600	0.012	0.024
θ	0°	8°	0°	8°

NOTES:

1. Body dimensions do not include mode flash or protrusion.
2. This drawing is subject to change without notice.

TAPE AND REEL INFORMATION

REEL DIMENSIONS



TAPE DIMENSIONS



NOTE: The picture is only for reference. Please make the object as the standard.

KEY PARAMETER LIST OF TAPE AND REEL

Package Type	Reel Diameter	Reel Width W1 (mm)	A0 (mm)	B0 (mm)	K0 (mm)	P0 (mm)	P1 (mm)	P2 (mm)	W (mm)	Pin1 Quadrant
SOT-23-6	7"	9.5	3.17	3.23	1.37	4.0	4.0	2.0	8.0	Q3

000001

PACKAGE INFORMATION

CARTON BOX DIMENSIONS



NOTE: The picture is only for reference. Please make the object as the standard.

KEY PARAMETER LIST OF CARTON BOX

Reel Type	Length (mm)	Width (mm)	Height (mm)	Pizza/Carton
7" (Option)	368	227	224	8
7"	442	410	224	18

DD0002