



SGM6609

High-Current, Synchronous Boost Converter with Adjustable Current Limit

GENERAL DESCRIPTION

The SGM6609 is a high-current, synchronous boost DC/DC converter with a programmable peak current limit. The peak current limit is programmed from 0.5A to 3.5A by an external resistor from ISET pin to ground. The device also uses an external resistive divider to set the output voltage from 3V to 5V.

This device has the input current protection to avoid overload of system power. When applying a large load pulse, it uses a selectable large capacitor to ensure that the output voltage meets the load power requirement. At light loads, the light load switching frequency modulation and low I_Q help the device maintain high efficiency. It also has the features like synchronous boost rectification and internal compensation. And the internal compensation offers a fast transient response with no external components.

This device also integrates a reverse current blocking to avoid current flowing back to the input. In shutdown mode, the input and output are isolated by the true load disconnection function. The device also includes over-temperature protection, short-circuit protection and programmable over-voltage protection.

The SGM6609 is available in Green TDFN-3×3-12L package and is rated over the -40 °C to +85 °C temperature range.

FEATURES

- **2.4V to 5V Input Voltage Range**
- **3V to 5V Adjustable Output Voltage**
- **0.5A to 3.5A Programmable N-MOSFET Peak Current Limit**
- **Up to 95%Efficiency**
- **1.2MHz Switching Frequency**
- **Synchronous Boost Rectification and Internal Compensation**
- **Reverse Current Blocking**
- **True Load Disconnection in Shutdown**
- **Power-Good Indication**
- **Programmable Over-Voltage Protection**
- **Over-Temperature and Short-Circuit Protection**
- **Available in a Green TDFN-3×3-12L Package**
- **-40°C to +85°C Operating Temperature Range**

APPLICATIONS

Industry and USB Modems
PC (PCMCIA) Modems Cards
PCI-E Modem Cards
WCDMA/Edge/GPRS/TD-SCDMA
CDMA/Evdo-A/Evdo-B

PACKAGE/ORDERING INFORMATION

MODEL	PACKAGE DESCRIPTION	SPECIFIED TEMPERATURE RANGE	ORDERING NUMBER	PACKAGE MARKING	PACKING OPTION
SGM6609	TDFN-3x3-12L	-40°C to +85°C	SGM6609YTDF12G/TR	SGM 6609DF XXXXX	Tape and Reel, 4000

MARKING INFORMATION

NOTE: XXXXXX = Date Code and Vendor Code.

XXXXX

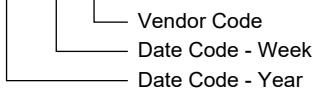

Green (RoHS & HSF): SG Micro Corp defines "Green" to mean Pb-Free (RoHS compatible) and free of halogen substances. If you have additional comments or questions, please contact your SGMICRO representative directly.

ABSOLUTE MAXIMUM RATINGS

- Input Supply Voltage Range -0.3V to 6V
- Supply Voltage on SW, VOUT, EN, FB, \overline{PG} -0.3V to 6V
- PGND to AGND -0.3V to 0.3V
- Package Thermal Resistance
- TDFN-3x3-12L, θ_{JA} 52.1°C/W
- Junction Temperature 150°C
- Storage Temperature Range -65°C to +150°C
- Lead Temperature (Soldering, 10s) 260°C
- ESD Susceptibility
- HBM 4000V
- MM 200V

RECOMMENDED OPERATING CONDITIONS

- Input Voltage Range 2.4V to 5.0V
- Operating Temperature Range -40°C to +85°C

OVERSTRESS CAUTION

Stresses beyond those listed in Absolute Maximum Ratings may cause permanent damage to the device. Exposure to absolute maximum rating conditions for extended periods may affect reliability. Functional operation of the device at any conditions beyond those indicated in the Recommended Operating Conditions section is not implied.

ESD SENSITIVITY CAUTION

This integrated circuit can be damaged if ESD protections are not considered carefully. SGMICRO recommends that all integrated circuits be handled with appropriate precautions. Failure to observe proper handling and installation procedures can cause damage. ESD damage can range from subtle performance degradation to complete device failure. Precision integrated circuits may be more susceptible to damage because even small parametric changes could cause the device not to meet the published specifications.

DISCLAIMER

SG Micro Corp reserves the right to make any change in circuit design, or specifications without prior notice.

PIN CONFIGURATION

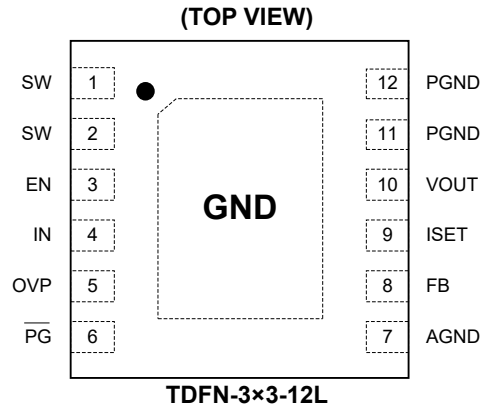

PIN DESCRIPTION

PIN	NAME	FUNCTION
1, 2	SW	Switching Node. Connect to the drain of internal N-MOSFET and source of internal P-MOSFET. Connect an external power inductor.
3	EN	Input Enable Pin. Logic high to enable this circuit and logic low to disable it.
4	IN	Input Voltage. When starts up, this pin supplies the device.
5	OVP	Over-Voltage Protection Pin. An external resistor divider is used to set the over-voltage threshold. Short this pin to ground to stop this function.
6	PG	Power-Good Signal (Active Low). When the feedback voltage exceeds 95% of the target voltage, this pin is pulled low.
7	AGND	Non-Power Signal Ground Pin.
8	FB	Feedback Input Pin. An external resistor divider is used to program the output voltage.
9	ISET	Peak Current Limit Programmable Input. An external resistor from this pin to ground is used to program the low-side MOSFET peak current limit.
10	VOUT	Boost Converter Output Voltage. Connect to the P-Channel synchronous MOSFET source. This pin is bypassed to GND with a ceramic capacitor.
11, 12	PGND	Power Ground. Internally connect to the source of the low-side NMOSFET.
Exposed Pad	GND	Power Ground Exposed Pad. Must be connected to ground plane.

ELECTRICAL CHARACTERISTICS(V_{IN} = 3.3V, V_{OUT} = 3.8V, L = 2.2μH, AGND = PGND, T_A = +25°C, unless otherwise noted.)

PARAMETER	SYMBOL	CONDITIONS	MIN	TYP	MAX	UNITS
Input Voltage Range	V _{IN}		2.4		5.0	V
Minimum Start-Up Voltage	V _{IN(MIN)}			2.3		V
Output Voltage Range	V _{OUT}		3.0		5.0	V
Input Under-Voltage Lockout	V _{UVLO}	V _{IN} Rising, Hysteresis = 0.2V	2.15	2.25	2.35	V
Quiescent Supply Current	I _Q	No-Load Current; Not Switching		50	70	μA
Shutdown Supply Current	I _{SHDN}	V _{EN} = GND, V _{IN} = 5.0V			1	μA
Feedback Accuracy	V _{FB}	T _A = +25°C, V _{FB} = 600mV	-2		+2	%
		T _A = -40°C to +85°C, V _{FB} = 600mV	-3		+3	
Feedback Leakage Current	I _{FB}	V _{FB} = 0 to 1.0V	-1		+1	μA
Load Regulation	ΔV _{OUT} /I _{OUT}	V _{IN} = 3.3V, V _{OUT} = 3.8V, 0 to 2.5A Load		1		%/A
Line Regulation	ΔV _{OUT} /V _{IN}	V _{IN} = 2.4V to V _{OUT} , I _{OUT} = 10mA		0.3		%/V
Output Over-Voltage Protection Threshold	V _{OVF}		0.55	0.60	0.65	V
Switching Frequency	f _{SW}			1.2		MHz
Maximum Duty Cycle	D			90		%
Minimum On-Time	t _{ON(MIN)}			80		ns
High-side P-Channel On-Resistance	R _{ON(PMOS)}			140		mΩ
Low-side N-Channel On-Resistance	R _{ON(NMOS)}			80		mΩ
Low-side Peak Current Limit Threshold	I _{LIMPK}	T _A = +25°C, R _{SET} = 60.4kΩ	1.9	2.55	3.2	A
Enable, Power-Good and Start-Up Features						
Logic Input Threshold High for EN	V _{IH}		1.5			V
Logic Input Threshold Low for EN	V _{IL}				0.4	V
EN Input Low Current	I _{EN}	V _{EN} = GND or 5.0V	-1	0.01	4	μA
Power-Good Threshold		FB Rising, Hysteresis = 10%		95		%
PG On-Resistance	R _{PG}	V _{FB} = 0.62V, I _{SINK} = 10μA		450		Ω
Thermal						
Over-Temperature Shutdown Threshold	T _{SD}	Temperature Rising		150		°C
Over-Temperature Shutdown Hysteresis	T _{HYS}			20		°C

TYPICAL PERFORMANCE CHARACTERISTICS

$V_{IN} = 3.3V$, $V_{OUT} = 3.8V$, $L = 2.2\mu H$, $AGND = PGND$, $T_A = +25^\circ C$, unless otherwise noted.

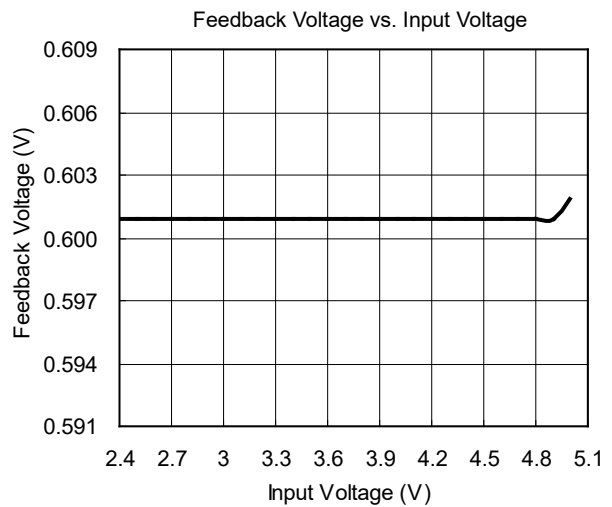
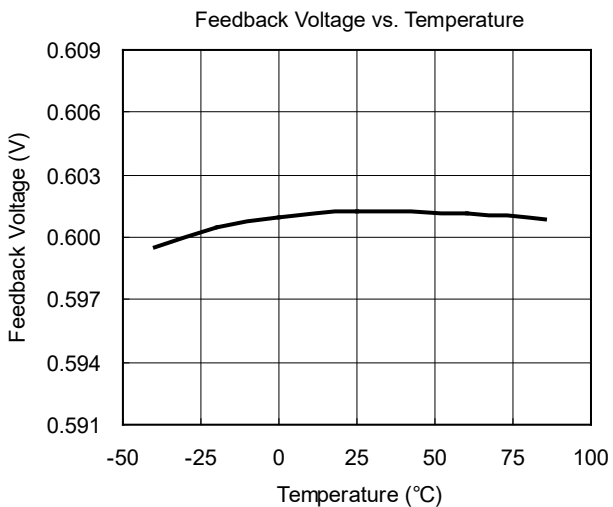
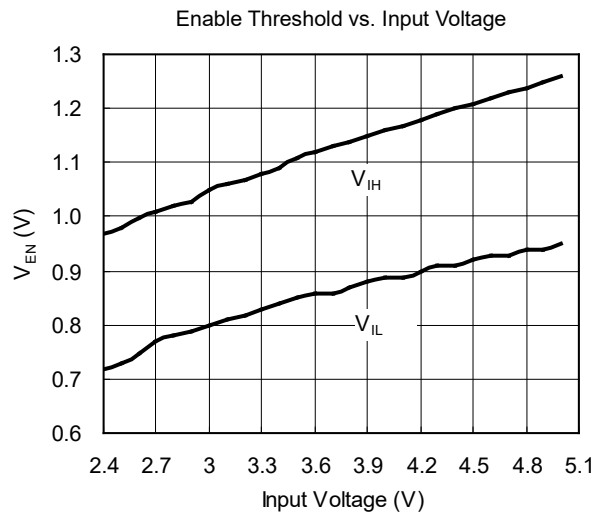
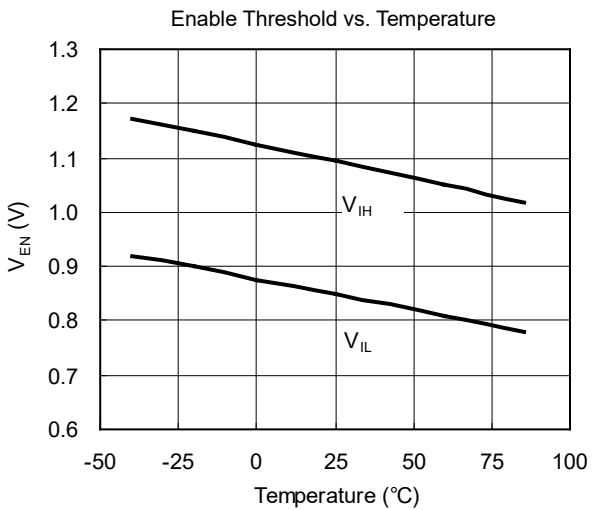
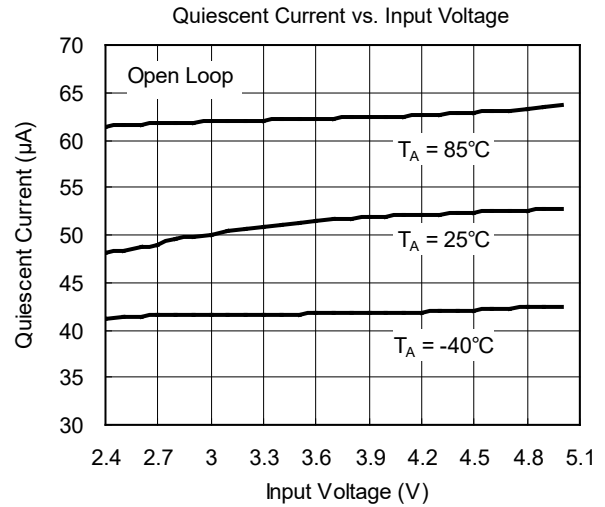
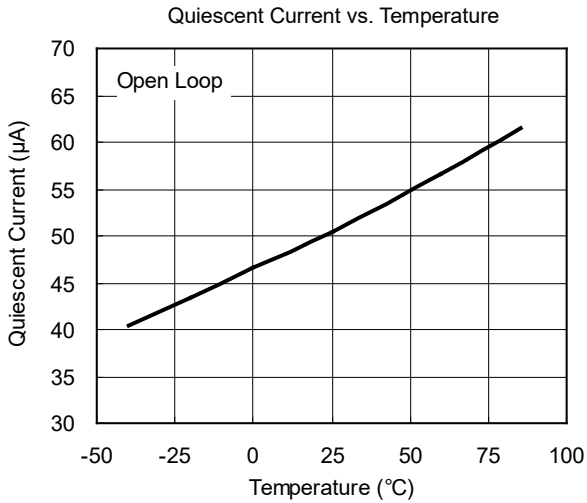

TYPICAL PERFORMANCE CHARACTERISTICS

$V_{IN} = 3.3V$, $V_{OUT} = 3.8V$, $L = 2.2\mu H$, $AGND = PGND$, $T_A = +25^\circ C$, unless otherwise noted.

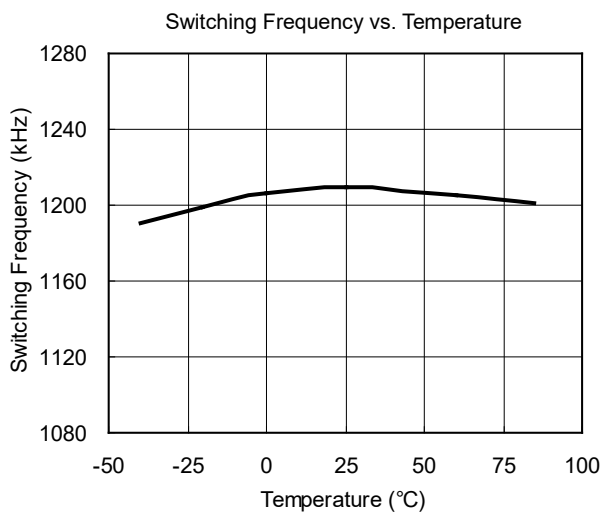
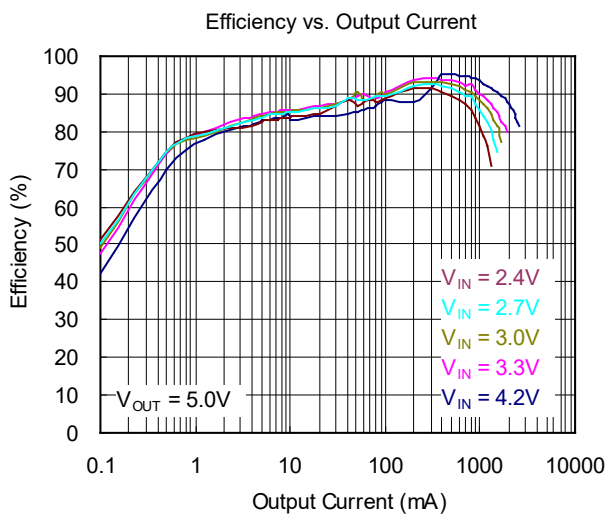
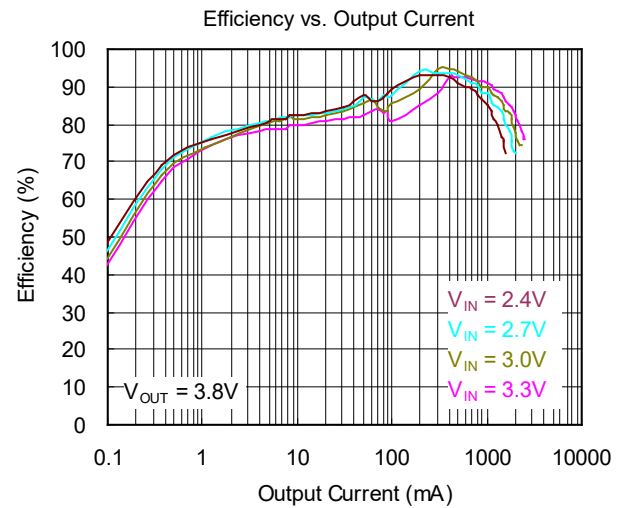
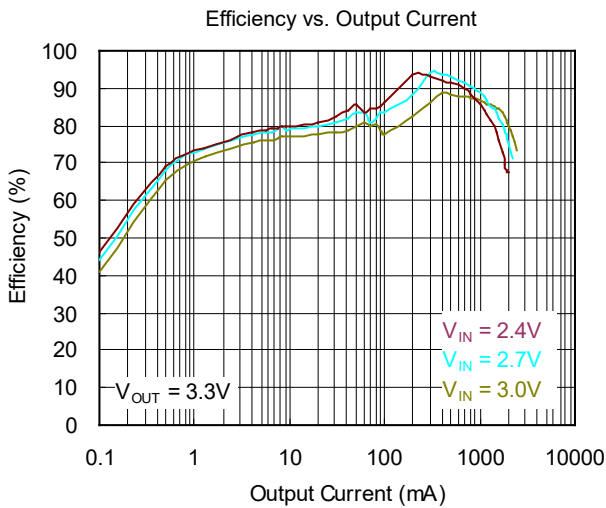
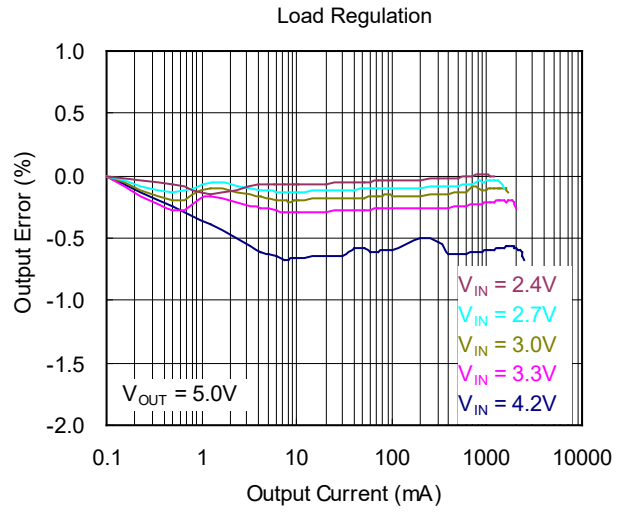
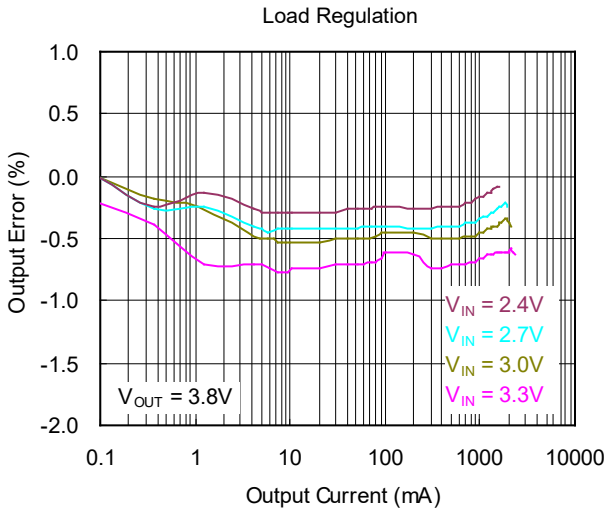

TYPICAL PERFORMANCE CHARACTERISTICS

$V_{IN} = 3.3V$, $V_{OUT} = 3.8V$, $L = 2.2\mu H$, $AGND = PGND$, $T_A = +25^\circ C$, unless otherwise noted.

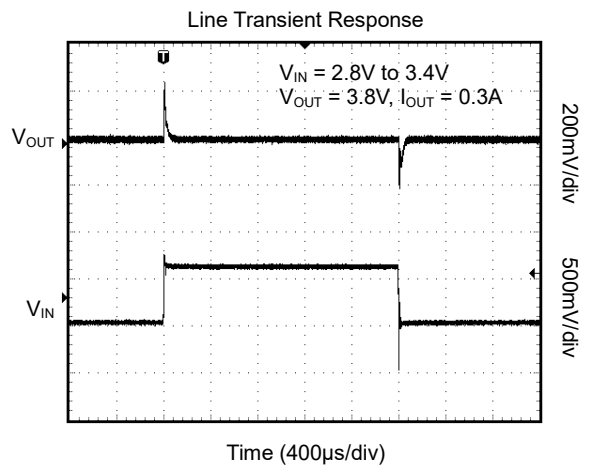
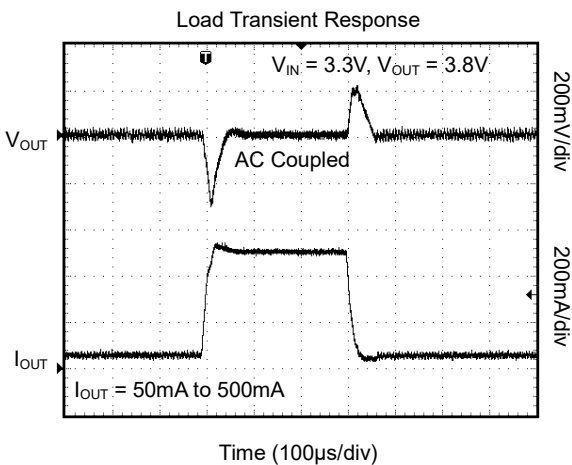
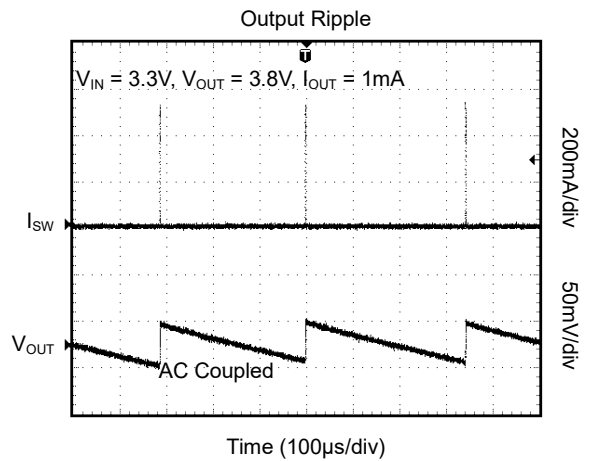
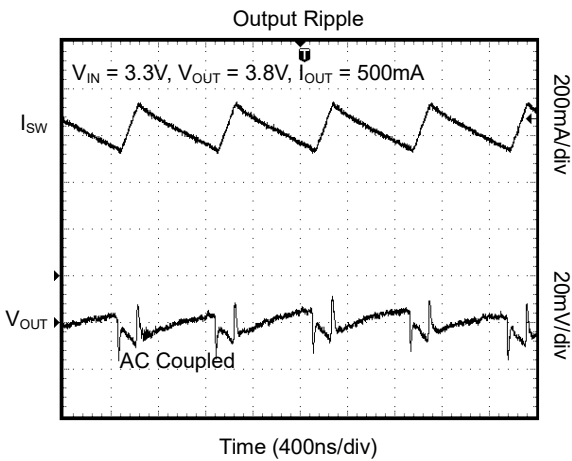
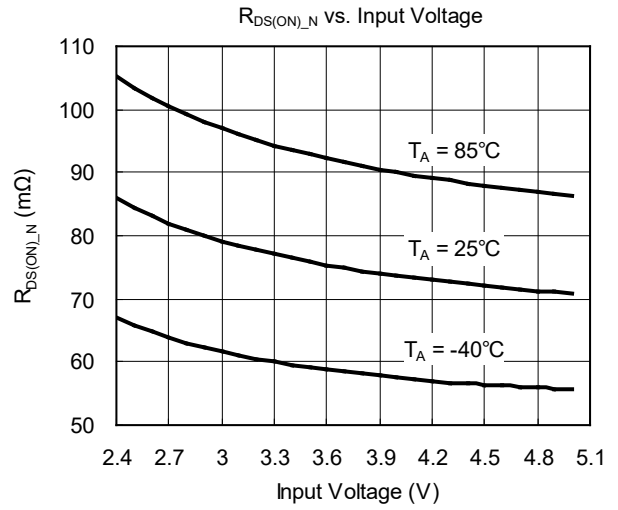
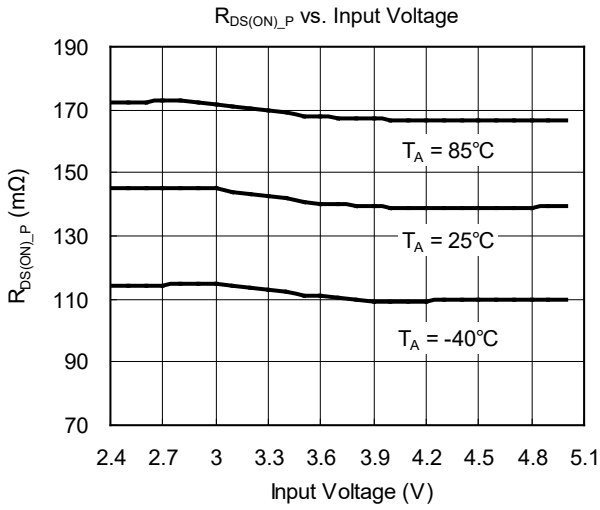

TYPICAL PERFORMANCE CHARACTERISTICS

$V_{IN} = 3.3V$, $V_{OUT} = 3.8V$, $L = 2.2\mu H$, $AGND = PGND$, $T_A = +25^\circ C$, unless otherwise noted.

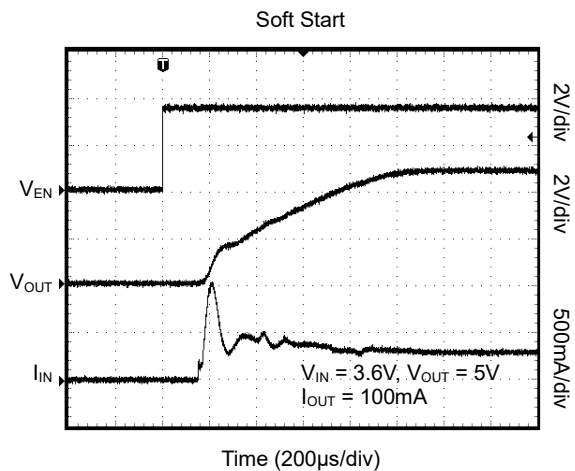

TYPICAL APPLICATIONS

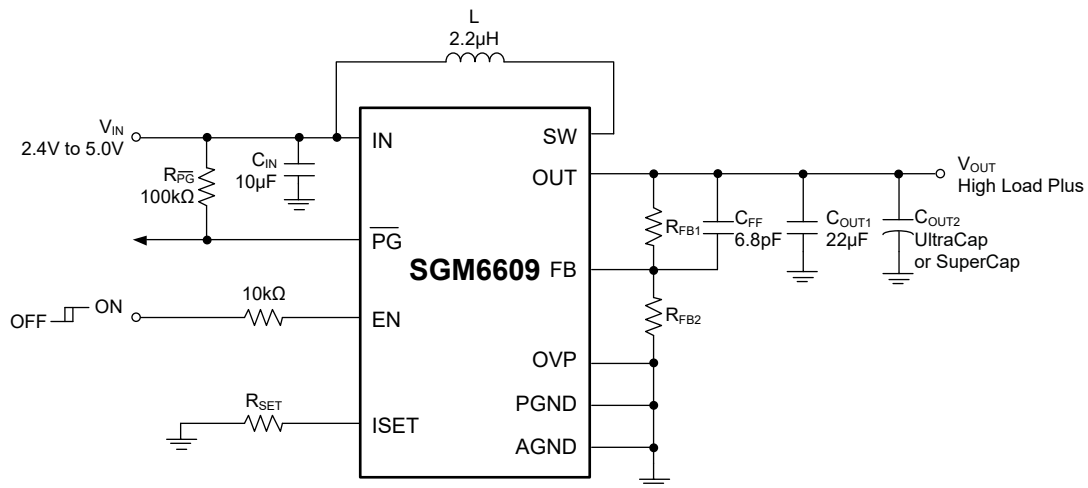
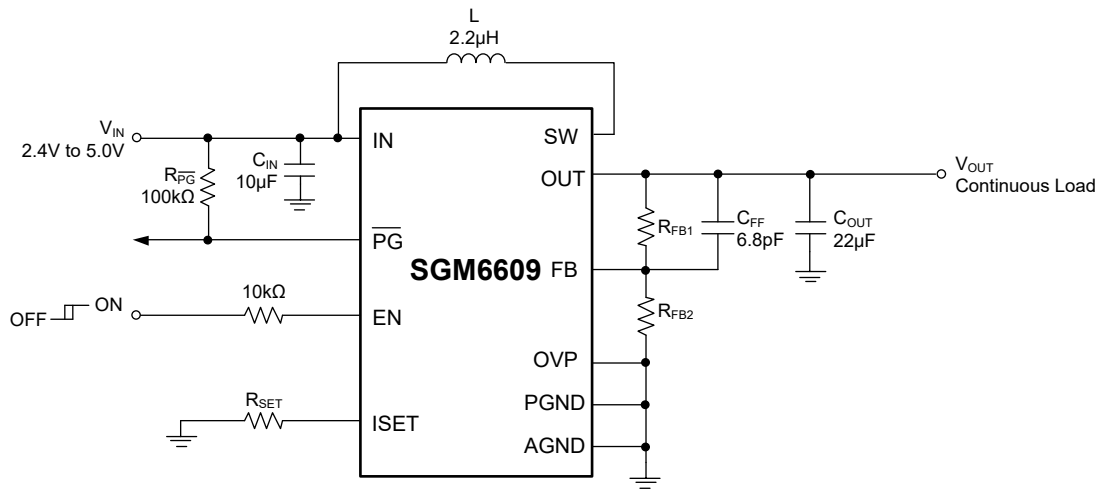

REVISION HISTORY

NOTE: Page numbers for previous revisions may differ from page numbers in the current version.

Changes from Original (FEBRUARY 2015) to REV.A

Page

Changed from product preview to production data.....All

PACKAGE OUTLINE DIMENSIONS

TDFN-3x3-12L

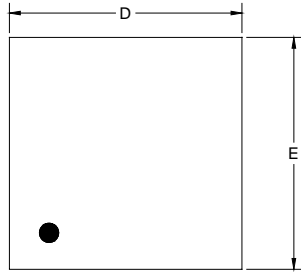

TOP VIEW

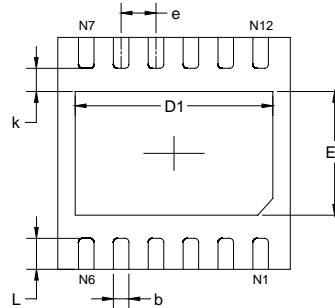

BOTTOM VIEW



SIDE VIEW

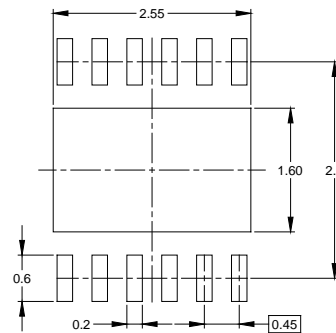

RECOMMENDED LAND PATTERN (Unit: mm)

Symbol	Dimensions In Millimeters		Dimensions In Inches	
	MIN	MAX	MIN	MAX
A	0.700	0.800	0.028	0.031
A1	0.000	0.050	0.000	0.002
A2	0.203 REF		0.008 REF	
D	2.924	3.076	0.115	0.121
D1	2.450	2.650	0.096	0.104
E	2.924	3.076	0.115	0.121
E1	1.500	1.700	0.059	0.067
k	0.200 MIN		0.008 MIN	
b	0.150	0.250	0.006	0.010
e	0.450 TYP		0.018 TYP	
L	0.324	0.476	0.013	0.019

NOTE: This drawing is subject to change without notice.

PACKAGE INFORMATION

TAPE AND REEL INFORMATION

REEL DIMENSIONS



TAPE DIMENSIONS



NOTE: The picture is only for reference. Please make the object as the standard.

KEY PARAMETER LIST OF TAPE AND REEL

Package Type	Reel Diameter	Reel Width W1 (mm)	A0 (mm)	B0 (mm)	K0 (mm)	P0 (mm)	P1 (mm)	P2 (mm)	W (mm)	Pin1 Quadrant
TDFN-3×3-12L	13"	12.4	3.30	3.30	1.10	4.0	8.0	2.0	12.0	Q1

000001

PACKAGE INFORMATION

CARTON BOX DIMENSIONS



NOTE: The picture is only for reference. Please make the object as the standard.

KEY PARAMETER LIST OF CARTON BOX

Reel Type	Length (mm)	Width (mm)	Height (mm)	Pizza/Carton
13"	386	280	370	5

DD0002